

Differential Housing Cover

Material

Item	Specification
Motorcraft® SAE 75W-140 Synthetic Rear Axle Lubricant XY-75W140-QL (US); CXY-75W140-1L (Canada)	WSL-M2C192-A and GL-5
Silicone Gasket and Sealant TA-30	WSE-M4G323-A4

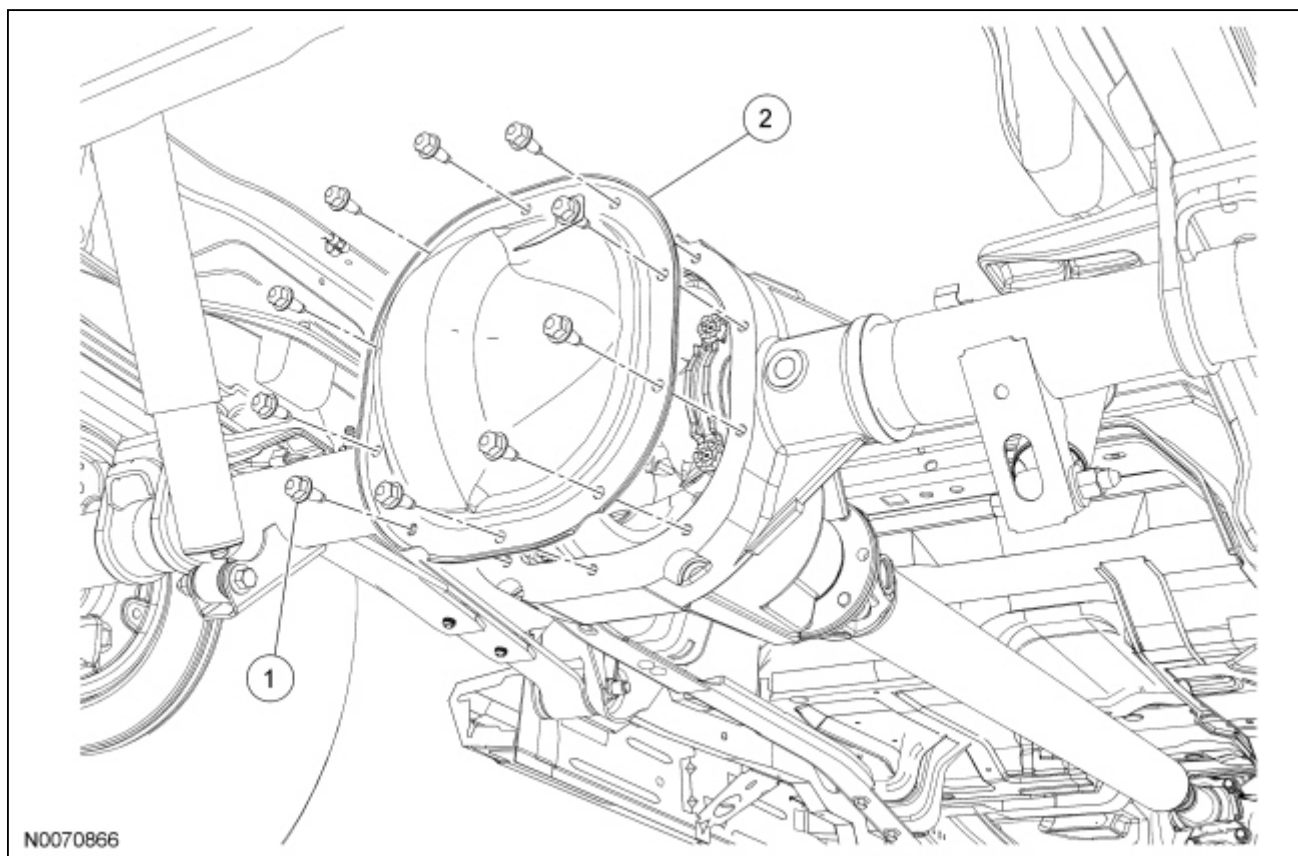

N0070866

Item	Part Number	Description
1	4346	Differential housing cover bolt (10 required)
2	4033	Differential housing cover

Removal

1. With the vehicle in NEUTRAL, position it on a hoist. For additional information, refer to [Section 100-02](#).
2. Remove the differential housing cover.
 1. Remove the 10 differential housing cover bolts and drain the lubricant from the axle housing.
 2. Remove the differential housing cover.

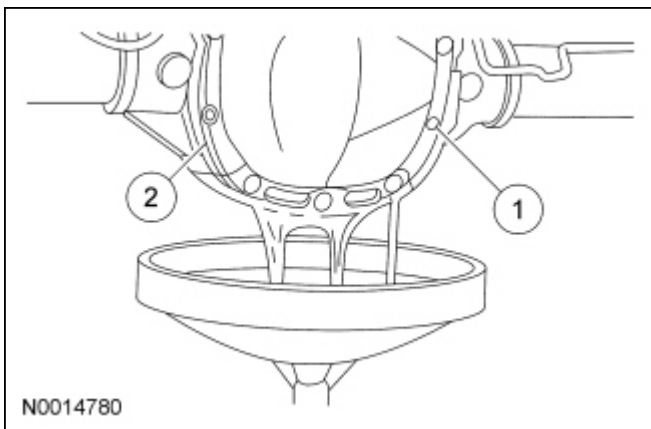

Installation

1. **NOTICE:** Make sure the machined surfaces on both the axle housing and the differential housing cover are clean and free of oil before installing the new silicone sealant. The inside of the axle housing must be covered when cleaning the machined surface to prevent contamination.

Clean the gasket mating surface of the axle housing and the differential housing cover.

2. Apply a new continuous bead of sealant to the differential housing cover.

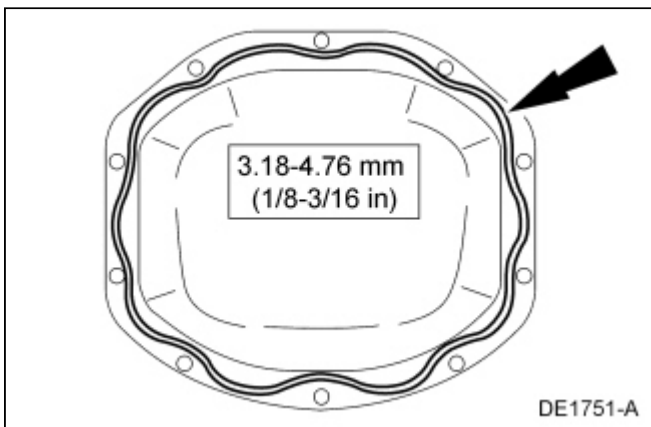

3. **NOTE:** The differential housing cover must be installed within 15 minutes of application of the silicone sealant, or new sealant must be applied. If possible, allow one hour before filling the axle housing with axle lubricant to make sure the silicone sealant has cured.

Install the differential housing cover and the differential housing cover bolts.

- Tighten to 46 Nm (33 lb-ft).

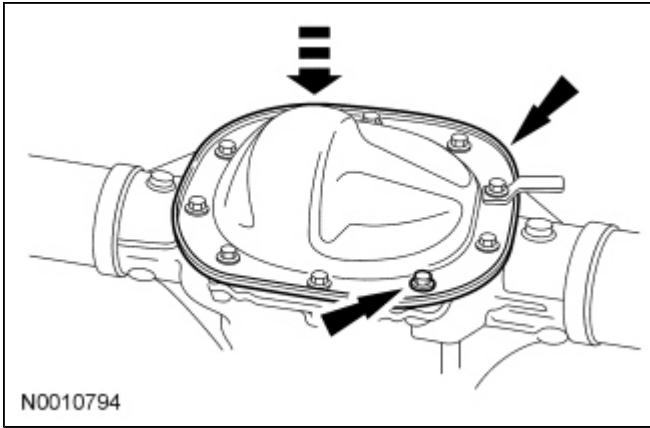

4. **NOTE:** Service refill capacities are determined by filling the axle to the bottom of the fill hole with the axle at ride height.

Remove the axle plug, fill the axle with 1.89-2.01L (4-4.25 pt) of axle lubricant and install the filler plug.

- Tighten to 30 Nm (22 lb-ft).
-